

# DESIGN NOTES

## LTC1645 Dual Channel Hot Swap Controller/Power Sequencer Allows Insertion Into a Live Backplane – Design Note 217

Bill Poucher

The LTC<sup>®</sup>1645 is a two-channel Hot Swap<sup>™</sup> controller and power sequencer that allows a board to be safely inserted and removed from a live backplane. When a board is hot swapped, the supply bypass capacitors on the board can draw huge transient currents from the backplane power bus as they charge. These transient currents can cause permanent damage to the capacitors, connector pins and board traces and can disrupt the system supply, causing other boards in the system to reset.

Using external N-channel pass transistors, supply voltages from 1.2V to 12V can be ramped together or separately at a programmable rate. Programmable electronic circuit breakers protect against shorts at either output. The LTC1645 is available in 14- and 8-pin SO packages. The 8-pin version includes a control input, dual gate drives and dual circuit breakers. The 14-pin version additionally provides a system reset signal and a spare comparator to indicate when board supply voltages drop below programmable levels. It also has a fault signal to indicate an overcurrent condition, as well as a timer pin to

create a delay before ramping up the supply voltages and before deasserting the system reset signal.

### Basic Operation

The LTC1645 controls a board's power supplies with external N-channel pass transistors in the power paths as shown in Figure 1 and Figure 3. The LTC1645 contains an internal charge pump to provide high side drive to the N-channel FETs. R<sub>SENSE1</sub> and R<sub>SENSE2</sub> provide current fault detection, and R1 and R2 prevent high frequency oscillation. By ramping the gates of the pass transistors up and down at a controlled rate, the transient surge current ( $I = C \cdot dv/dt$ ) drawn from the main backplane supply, is limited to a safe value when the board makes connection.

Taking the ON pin above 0.8V turns on GATE1 after one timing cycle, while taking the ON pin above 2V turns GATE2 on if the ON pin has been above 0.8V for at least

LT, LTC and LT are registered trademarks of Linear Technology Corporation. Hot Swap is a trademark of Linear Technology Corporation.

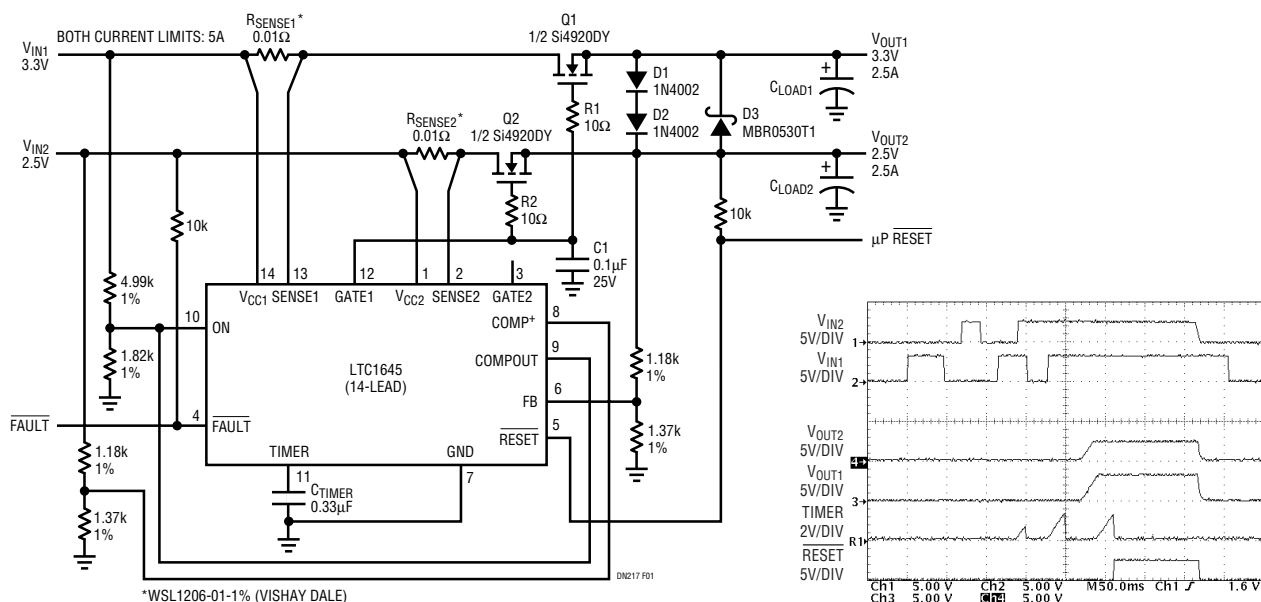

Figure 2. Ramping 3.3V and 2.5V Up and Down Together

Figure 2. Supply Tracking Waveforms

one timing cycle. The circuit breaker trips whenever the voltage across either sense resistor is greater than 50mV for more than 1.5 $\mu$ s. When it trips, both GATE pins are immediately pulled to ground, the external FETs are quickly turned off and (in the 14-pin version) FAULT is asserted.

The 14-pin version of the LTC1645 provides two open-drain output comparators for monitoring input or output voltage levels. One releases RESET one timing cycle after the FB pin exceeds 1.238V, while the other releases COMPOUT immediately whenever COMP<sup>+</sup> is above 1.238V.

### Power Supply Tracking and Sequencing

In addition to general purpose hot swapping, the LTC1645 helps simplify power supply tracking and sequencing circuits. Some applications require that the difference between two power supplies never exceed a certain voltage. This requirement applies during power-up and power-down as well as during steady-state operation, often to prevent latch-up in a dual-supply ASIC. Other systems require one supply to come up after another; for example, when a system clock needs to start before a block of logic. Typical dual supplies or backplane connections may come up at arbitrary rates depending on load current, capacitor size, soft-start rates, etc. Traditional solutions can be cumbersome or require complex circuitry to meet the necessary requirements.

Figure 1 shows an application ramping V<sub>OUT1</sub> and V<sub>OUT2</sub> up and down together. The ON pin must reach 0.8V to ramp up V<sub>OUT1</sub> and V<sub>OUT2</sub>. The spare comparator pulls the ON pin low until V<sub>IN2</sub> is above 2.3V, and the ON pin cannot reach 0.8V before V<sub>IN1</sub> is above 3V. Thus, both input supplies must be within regulation before a timing cycle can start. At the end of the timing cycle, the output voltages ramp up together. If either input supply falls out of regulation or if an overcurrent condition is detected, the gates of Q1 and Q2 are pulled low together. Figure 2 shows an oscilloscope photo of the circuit in Figure 1.

On power-up, V<sub>OUT1</sub> and V<sub>OUT2</sub> ramp up together. On power-down, the LTC1645 turns off Q1 and Q2 simultaneously. Charge remains stored on C<sub>LOAD1</sub> and C<sub>LOAD2</sub> and the output voltages will vary depending on the loads. D1 and D2 turn on at  $\approx 1V$  ( $\approx 0.5V$  each), ensuring that

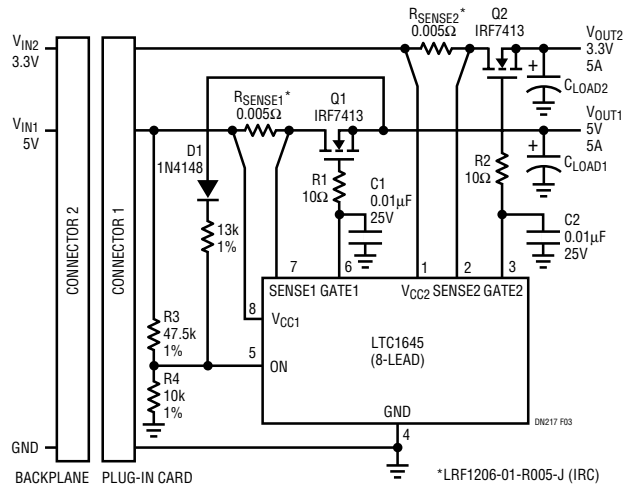

Figure 3. Supply Sequencing

V<sub>OUT1</sub> never exceeds V<sub>OUT2</sub> by more than 1.2V. D3 guarantees V<sub>OUT2</sub> is never greater than V<sub>OUT1</sub> by more than 0.4V. Barring an overvoltage condition at the input(s), the only time these diodes might conduct current is during a power-down event, and then only to discharge C<sub>LOAD1</sub> or C<sub>LOAD2</sub>. In the case of an input overvoltage condition that causes excess current to flow, the circuit breaker will trip if the current limit level is set appropriately.

Figure 3 shows the LTC1645 in a Hot Swap application configured to ramp up V<sub>OUT1</sub> before V<sub>OUT2</sub>. V<sub>OUT1</sub> is initially discharged and D1 is reverse-biased, thus the voltage at the ON pin is determined only by V<sub>CC1</sub> through the resistor divider R3 and R4. If V<sub>CC1</sub> is above 4.6V, the voltage at the ON pin exceeds 0.8V and V<sub>OUT1</sub> ramps up. As V<sub>OUT1</sub> ramps up, D1 forward-biases and pulls the ON pin above 2V when V<sub>OUT1</sub>  $\approx 4.5V$ . This turns on GATE2 and V<sub>OUT2</sub> ramps up. Use the 14-pin version if additional voltage monitoring is desired.

### Conclusion

Designing hot insertion systems normally requires a significant effort by an experienced analog designer. With the LTC1645, safe and reliable hot swapping becomes as easy as hooking up an IC, a couple of power FETs and a handful of resistors and capacitors.

#### Data Sheet Download

<http://www.linear-tech.com/go/dnLTC1645>

For literature on our Hot Swap Controllers, call **1-800-4-LINEAR**. For applications help, call (408) 432-1900, Ext. 2453